

SCHALTPLAN / WIRING DIAGRAM

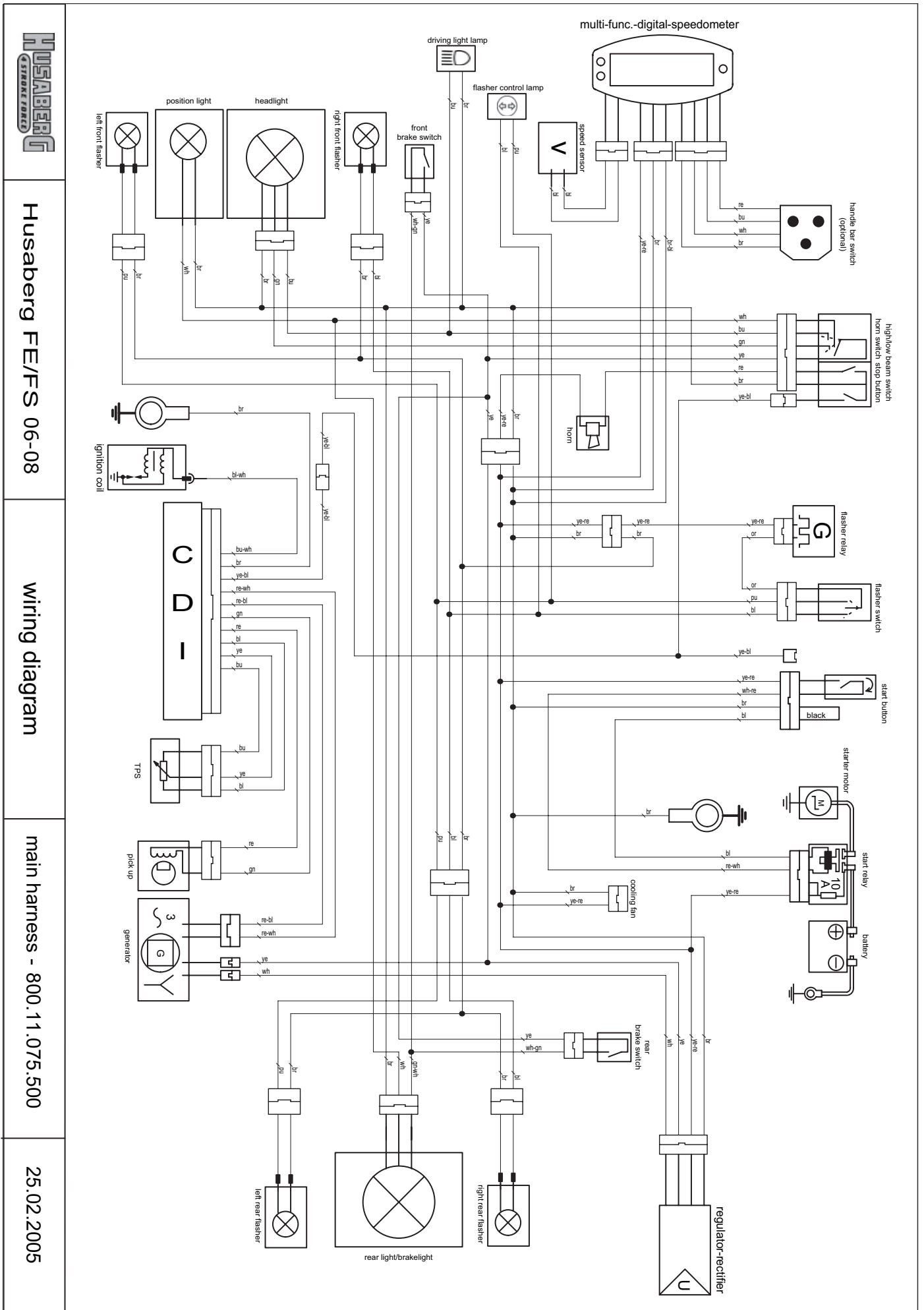

Husaberg FE/FS 06-08

wiring diagram

main harness - 800.11.075.500





25.02.2005

SCHALTPLAN / WIRING DIAGRAM

horn switch

cable color	re	br
HORN 	●	●
OFF		



light switch
high/low beam switch

cable color	bu	ye	gn	wh
LIGHT OFF				
P.LIGHT 		●	●	●
LO 		●	●	
HI 	●	●		
P.LIGHT 		●	●	

brake switch

cable harness	gn-wh	ye
cable switch	bl	bl
pushed	●	●
unpushed		

flasher switch

cable harness	or	pu	bl
TURN L 	●	●	
TURN R 	●	●	●
OFF			

start switch

cable switch	re-wh	ye-re
START 	●	●
unpushed		

kill switch

cable color	ye-bl	br
pushed	●	●
unpushed		

SCHALTPLAN / WIRING DIAGRAM

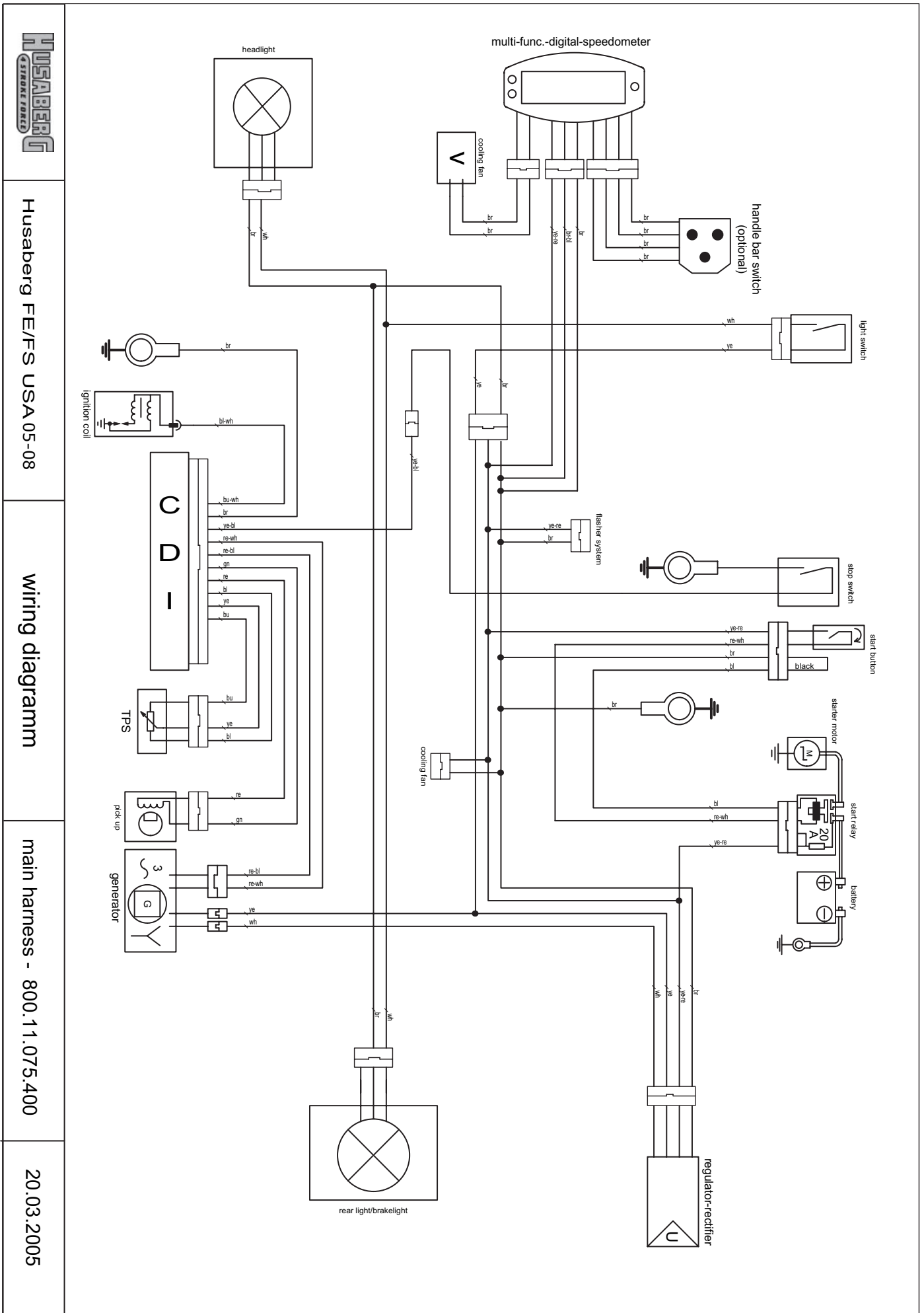

Husaberg FE/FS USA 05-08

wiring diagramm

main harness - 800.11.075.400

20.03.2005

SCHALTPLAN / WIRING DIAGRAM

ENGLISH	DEUTSCH	FRANCAIS
Battery Cooling fan Driving light lamp Flasher control lamp Flasher relay	Batterie Lüftermotor Fernlichtkontrolllampe Blinkerkontrollampe Blinkerrelais	Batterie Ventilateur temoin feu route temoin de clignoteur Relais de clignotants
Flasher switch Flasher system Front brake switch Generator Handle bar switch for multi-func.-digital-speedometer	Blinkerschalter Blinksystem vorderer Bremslichtschalter Generator Lenkerschalter für Multifunkt.Digitaltacho	Bouton de clignotants Systeme de clignotants Contacteur de frein avant Alternateur Contacteur au guidon pour ordinateur de bord
Headlight High / low beam switch Horn Horn switch Ignition coil	Scheinwerfer Auf-Abblendschalter Hupe Hornscharter Zündspule	Phare Contacteur code/phare Avertisseur sonore Bouton d'avertisseur sonore Bobine d'allumage
Ignition switch Left front flasher Left rear flasher Light switch Multi-func.-digital-speedometer	Zündschloss linker vorderer Blinker linker hinterer Blinker Lichtschalter Multifunktionsdigitaltacho	Contacteur d'allumage Clignotant avant gauche Clignotant arrière gauche Contacteur d'éclairage Ordinateur de bord
Pick up Position light Rear brake switch Rear light / brakelight Regulator-rectifier	Impulsgeber Begrenzungslicht hinterer Bremslichtschalter hinteres Begrenzungslicht / Bremslicht Regelgleichrichter	Capteur d'allumage feu de position Contacteur de frein arrière Feu rouge/stop Régulateur/redresseur
Right front flasher Right rear flasher Speed sensor Start relay Start/stop button	rechter vorderer Blinker Rechter hinterer Blinker Geschwindigkeitssensor Startrelais Start / Stop schalter	Clignotant avant droit Clignotant arrière droit Capteur de vitesse Relais de démarreur Contacteur start/stop
Starter motor Temperature switch Throttle position sensor (TPS)	Startermotor Temperaturschalter Vergaserpotentiometer	Démarreur Contacteur de température Capteur d'ouverture de carburateur

CABLE COLOURS	KABELFARBEN	COULEUR DE CABLE
bl: black ye: yellow bu: blue gn: green re: red wh: white br: brown or: orange pi: pink gr: grey pu: purple	bl: schwarz ye: gelb bu: blau gn: grün re: rot wh: weiß br: braun or: orange pi: rosa gr: grau pu: violett	bl: noir ye: jaune bu: bleu gn: vert re: rouge wh: blanc br: brun or: orange pi: rose gr: gris pu: violet